

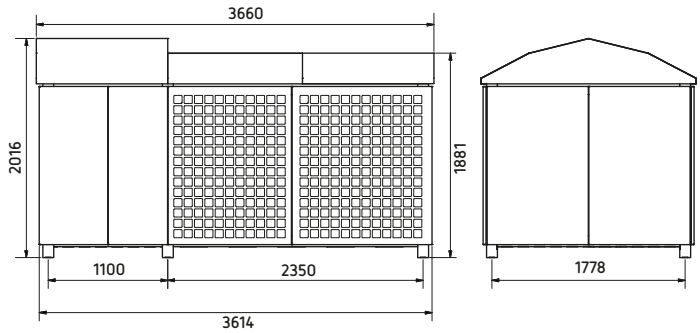

# DATA SHEET CAMBRIDGE

Air Source Heat Pump		
Product Name	Cambridge	
Model Number	CAM407CMOD1	
SSHEE (Ave conditions)	108%	
(Air 7°C/Water 35°C)*	Rated Output (kW)	82.5
	Power Consumption (kW)	25.1
	Rated COP	3.3
(Air 2°C/Water 35°C)*	Rated Output (kW)	79.3
	Power Consumption (kW)	27.6
	Rated COP	2.9
(Air -7°C/Water 35°C)*	Rated Output (kW)	67.3
	Power Consumption (kW)	26.0
	Rated COP	2.6
Domestic Hot Water Temperature (°C)	65	
Weight (kg)	1000	
Heat Pump Voltage / Frequency	400/415V 3~ 50Hz	
Max Running Current (A) Compressor	60	
Max Electrical Power (kVA) Compressor	54	
Sound Power Level @ 1m (dB)*	75	
Minimum Operating Temperature (°C)	-20	
Maximum Operating Temperature (°C)	30	



Model	H	W	D
Cambridge	1881	3660	1778

All sizes in mm

\* Test results as per BS EN14511

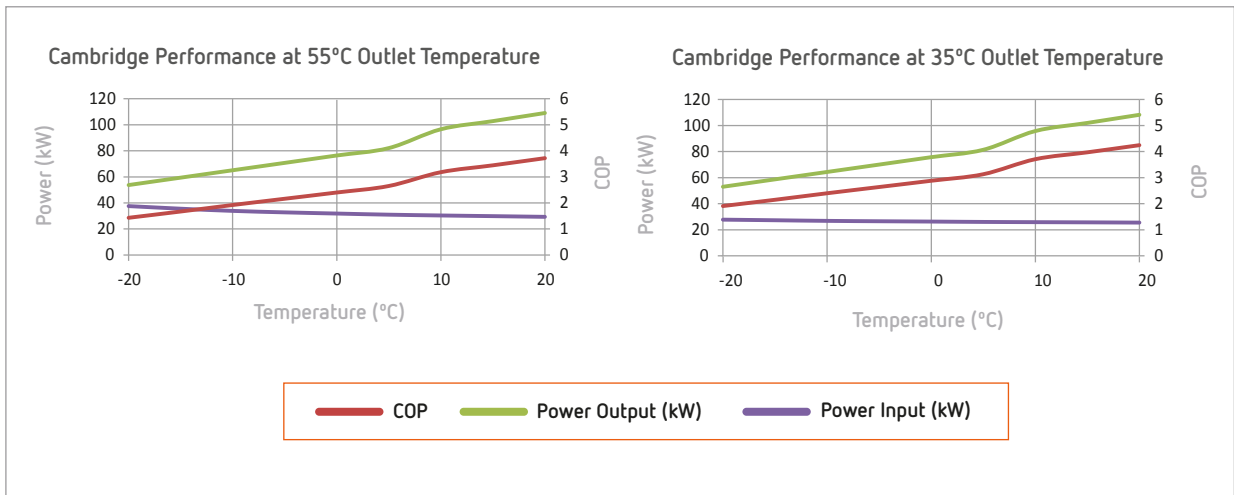

## CASE STUDY 1

- ✔ Large commercial space
- ✔ 2015 running costs £8000
- ✔ 40% emissions reduction
- ✔ RHI eligible

## 3500M<sup>2</sup> WAREHOUSE

The owners of this 3500m<sup>2</sup> warehouse and production hall were looking to hold the space at a working temperature of 19°C and remove the existing gas system. Based on a heat loss survey, and the client's expected pattern of air change through the large doors, a single Cambridge 100kW unit was specified. The air source heat pump was coupled with easy to install and commission ceiling mounted fan convectors, allowing both heat delivery and an element of destratification. The fan convectors were specified to allow low flow temperatures maximising the system efficiency.

In 2015 running costs were estimated at under £8,000. With anticipated payments from the RHI, total savings are estimated at £9,750 at 2015 prices.

Carbon emissions are expected to fall by up to 40%.

The Client commented: "After a full year of running, including a spell of cold weather last winter, we have been impressed with the new system. Maintenance is low and running costs have been better than last year, even before taking into account the subsidies."



## CASE STUDY 2

- ✔ Retro-fit school scheme
- ✔ Existing radiator system
- ✔ Gas boilers integrated
- ✔ RHI potential £8000 pa



## VICTORIAN SCHOOL

Clarence High School have a large, Victorian building with an equally large, radiator based system. Seeking to both control costs and reduce emissions whilst benefiting from the RHI, they looked to an air source heat pump. Given the scale of the existing radiator system and the costs of a full overhaul, a Cambridge 100kW heat pump was specified in tandem with gas boilers. This bivalent system uses the heat pump for the full heating season, with the gas boilers controlled by the heat pump, boosting the system flow temperatures. The gas boilers are only used when the output of the heat pump is insufficient to meet the target temperatures.

With potential RHI payments of up to £8000 a year, the project was justified without the need to demonstrate large savings on running costs.

Carbon emissions are expected to fall by up to 25% on the heat generated by the heat pump.

For more information visit [www.globalenergysystems.co.uk](http://www.globalenergysystems.co.uk) or call +44 (0) 3333 444 414

All estimates and savings correct at time of calculation.



Certificate Number MCS 1453  
Heat Pump Technology

